

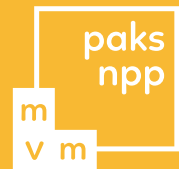

The operation of the Paks NPP



At the Paks Nuclear Power Plant there are four pressurized water reactor units are operating consisting of two closed water circuits; the primary and the secondary circuits. A special feature of pressurized water reactors is that the water of the primary circuit is under high pressure (123 bars), therefore the water would not boil even at temperature of 300 °C.

The primary circuit is a system-group including the nuclear reactor, the water circulating loops and pumps, the heat exchanger pipes of the steam generators and the pressurizer. Its main task is the nuclear based steam generation, to maintain the definitive pressure and temperature conditions, and to prevent the release of the coolant into the environment.

The secondary circuit is a system-group including the feed-water side of the steam generator, the main steam system, the high and low pressure elements of the turbine, the condenser and the feed-water system. Its main task is to transform the energy of the steam into rotating movement energy, which will be the driving force of the turbines and the generator.

The 1,485 MW energy generated in the reactor is carried to the steam generators by purified water circulated in closed loops. There the water of the primary circuit generates steam through the heat exchanger tubes in another closed water loop at 46 bar pressure and 260 °C. 2,940 tons of steam is generated per hour, having two large independent turbines rotated at a speed of 3,000 rpm. This rotating movement through mechanical connections generates 15,750 volts electricity in the generators through electromagnetic induction. This power then is transferred through switchboards and transformers to the national grid at 120 and 400 kV voltage level. There are auxiliary technological systems connected to the main equipment providing safety functions, improving efficiency of the power plant and continuously purifying the water loops. The "waste steam" having performed its job is then again transformed into water using the cooling effect of the river Danube. This water loop is an open one, the 100 cubic metres of water extracted per second from the river Danube is returned there approximately 8 °C warmer.

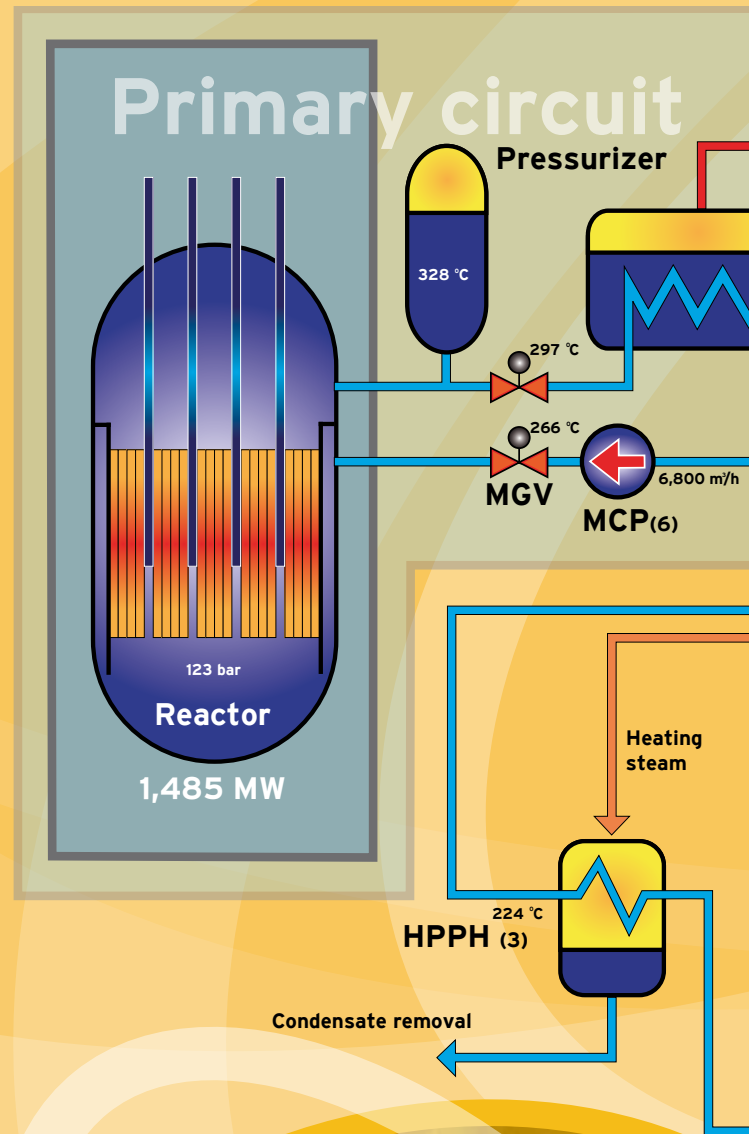

The scheme of main equipment taking part in power generation at Paks Nuclear Power Plant.

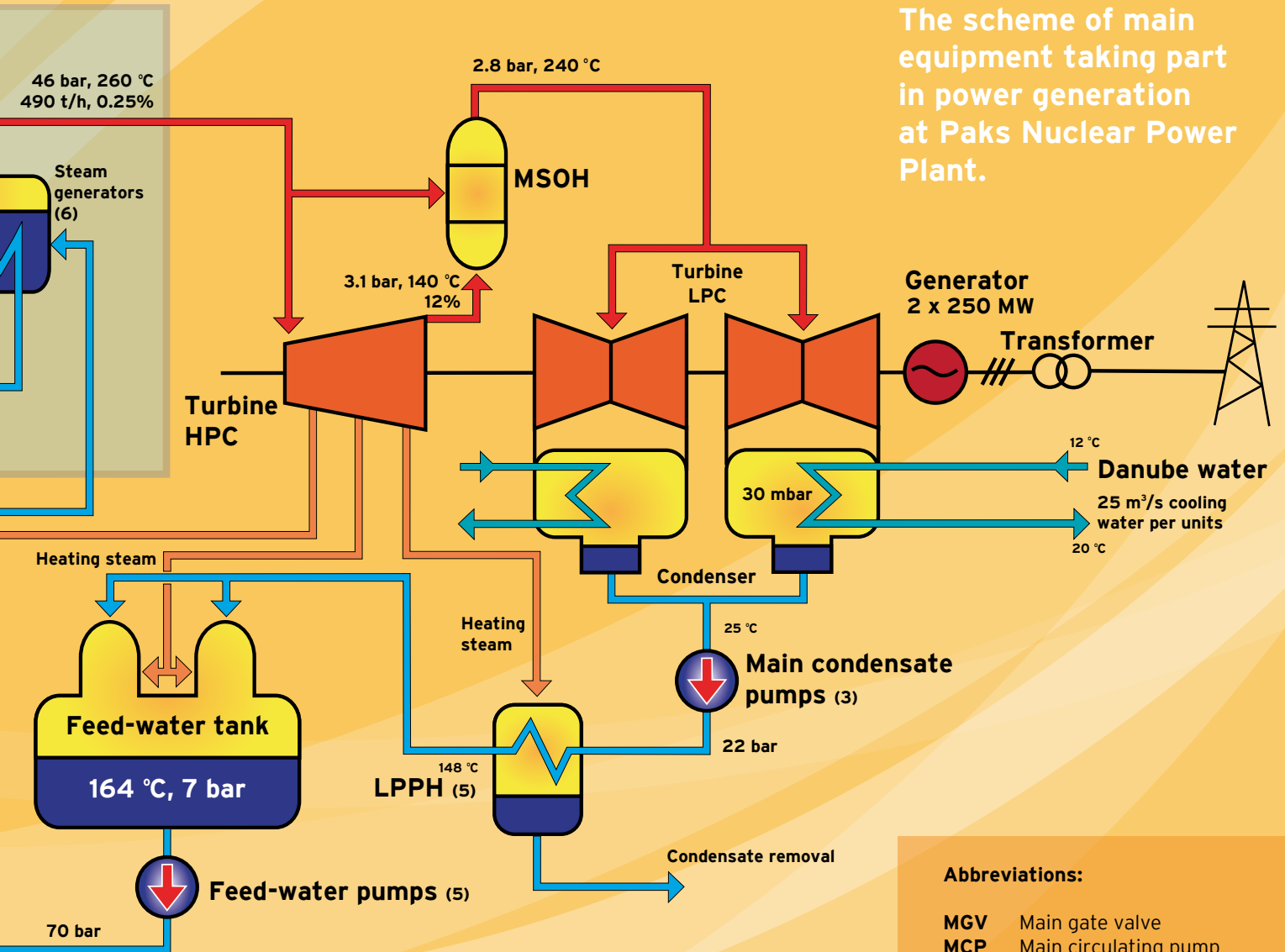

## Secondary circuit

### Abbreviations:

- MGV** Main gate valve
- MCP** Main circulating pump
- MSOH** Moisture separator  
overheater
- HPC** High pressure case
- LPC** Low pressure case
- HPPH** High pressure pre-heater
- LPPH** Low pressure pre-heater

Note: pressures are meant at absolute value.



**Public Information and  
Visitor Centre  
Contact information:**

Telephone:

+36 75 508 833,

+36 75 507 432

E-mail:

uzemlatogatas@npp.hu

**Opening times:**

Monday-Friday

**8.00–15.00 hours**

Saturday

**9.00–13.00 hours**

# Come, see, and understand!



**MVM Paks Nuclear Power Plant Plc.**

Address: 7031 Paks, P.O.B. 71, Lot No: 8803/17

Central switchboard and fax:

+36 75 505 000; +36 1 355-1332

Website: [www.atomeromu.hu](http://www.atomeromu.hu)

Facebook:

[www.facebook.com/paksiatomeromu](https://www.facebook.com/paksiatomeromu)